

610 Casing Jack-up



Futech Engineering Trading Co., Ltd.

Workshop: 123C Tin Ha Road, Hung Shui Kiu, Yuen Long, N.T.

Tel: 852-31181665 Fax: 852-31186557

E-mail: sales@chinahydraulic.com Website: www.chinahydraulic.com

Contents

Introduction	-----	3
Technical Specifications	-----	4
List of Parts	-----	5
Operation Regulations	-----	7
Maintenance Regulations	-----	8



Futech Engineering Trading Co., Ltd.

Workshop: 123C Tin Ha Road, Hung Shui Kiu, Yuen Long, N.T.

Tel: 852-31181665 Fax: 852-31186557

E-mail: sales@chinahydraulic.com Website: www.chinahydraulic.com

Introduction

Thank you for purchasing this Casing Jack-up machine and watching this manual.

610 Casing Jack-up machine is used in jacking up casing. After supplying electricity to power pack, it will output hydraulic pressure to Casing Jack-up machine. By using a control valve, hydraulic cylinders can be able to transform hydraulic pressure into force, so that it can clamp the casing and jack it up. This Casing Jack-up machine can be used on casing with a diameter 610mm, 406mm or 323mm. Jacking force can reach to 300 ton.

If there is any missing information in this manual, please contact us. Information can be changed over time. We reserve the right to make changes and corrections at any time, without notice. Please always refer to the updated version of Casing Jack-up machine manual.



Futech Engineering Trading Co., Ltd.

Workshop: 123C Tin Ha Road, Hung Shui Kiu, Yuen Long, N.T.

Tel: 852-31181665 Fax: 852-31186557

E-mail: sales@chinahydraulic.com Website: www.chinahydraulic.com

Technical Specifications

Casing Jack-up Machine

Dimension	1.1m (L) x 1.1m (W) x 1.53m (H)
Weight	~2 ton
Max. Jacking Force	300 ton
Time for 1 stroke	~40 s
Casing dimension	610/406/323mm

Power Pack

Dimension	2m (L) x 0.8m (W) x 1.3m (H)
Weight	~0.8 ton
Electric Motor	
Power	30kW
Input Voltage	3 Phase 380V ac
Switch	Star-Delta Starter
Hydraulic Pump	
Pump Type	Variable displacement piston pump
Pump Control	Pressure/flow/power control
Max. Hydraulic Pressure	380 bar



Futech Engineering Trading Co., Ltd.

Workshop: 123C Tin Ha Road, Hung Shui Kiu, Yuen Long, N.T.

Tel: 852-31181665 Fax: 852-31186557

E-mail: sales@chinahydraulic.com Website: www.chinahydraulic.com

List of Parts

項目號 (Item no.)	說明 (Description)	數量 (Quantity)
1	提升油缸 (Jack-up cylinder)	4
2	控制閥塊 (Control valve block)	1
3	銷 (Pin)	4
4	支撐座 (Support)	4
5A	610 夾具 (Clamping tools)	4
5B	406 夾具 (Clamping tools)	4
5C	323 夾具 (Clamping tools)	4
6	夾緊油缸 (Clamping cylinder)	4

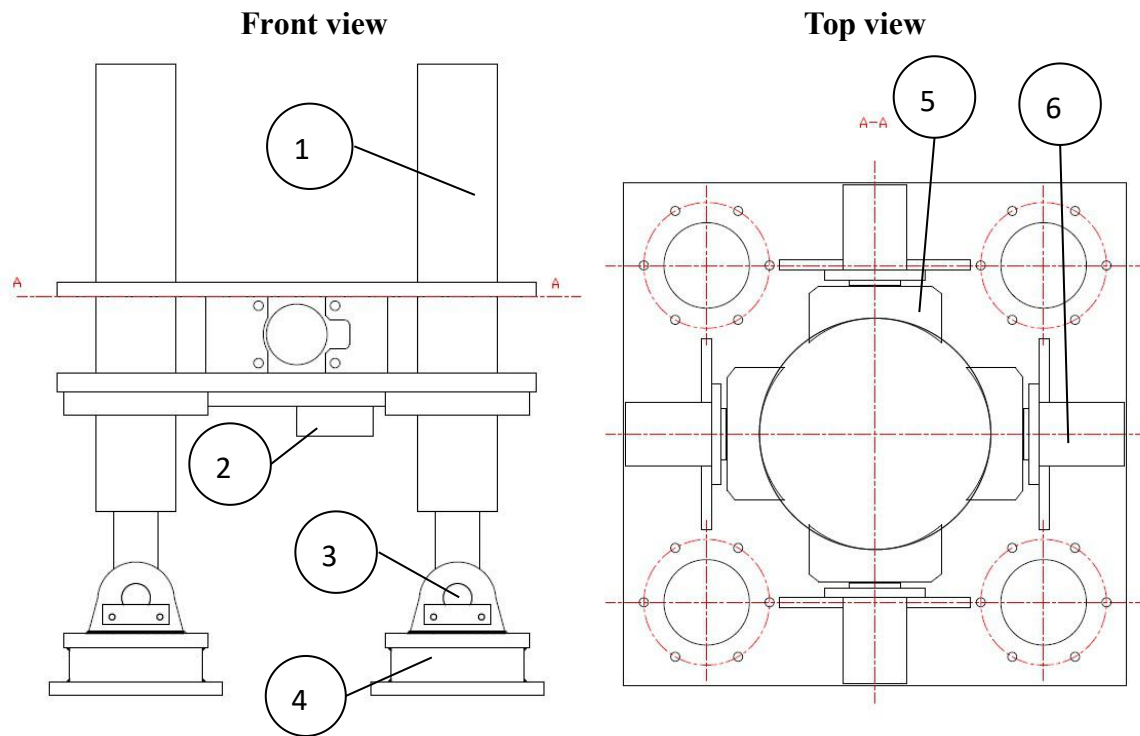

Futech Engineering Trading Co., Ltd.

Workshop: 123C Tin Ha Road, Hung Shui Kiu, Yuen Long, N.T.

Tel: 852-31181665 Fax: 852-31186557

E-mail: sales@chinahydraulic.com Website: www.chinahydraulic.com

項目號 (Item no.)	說明 (Description)	數量 (Quantity)
1	冷卻器 (Cooler)	1
2	油壓泵 (Hydraulic Pump)	1
3	電馬達 (Electric Motor)	1
4	電箱 (Switch Box)	1
5	油箱 (Oil Tank)	1
6	回油過濾器 (Return Filter)	1
7	控制閥 (Control Valve)	1

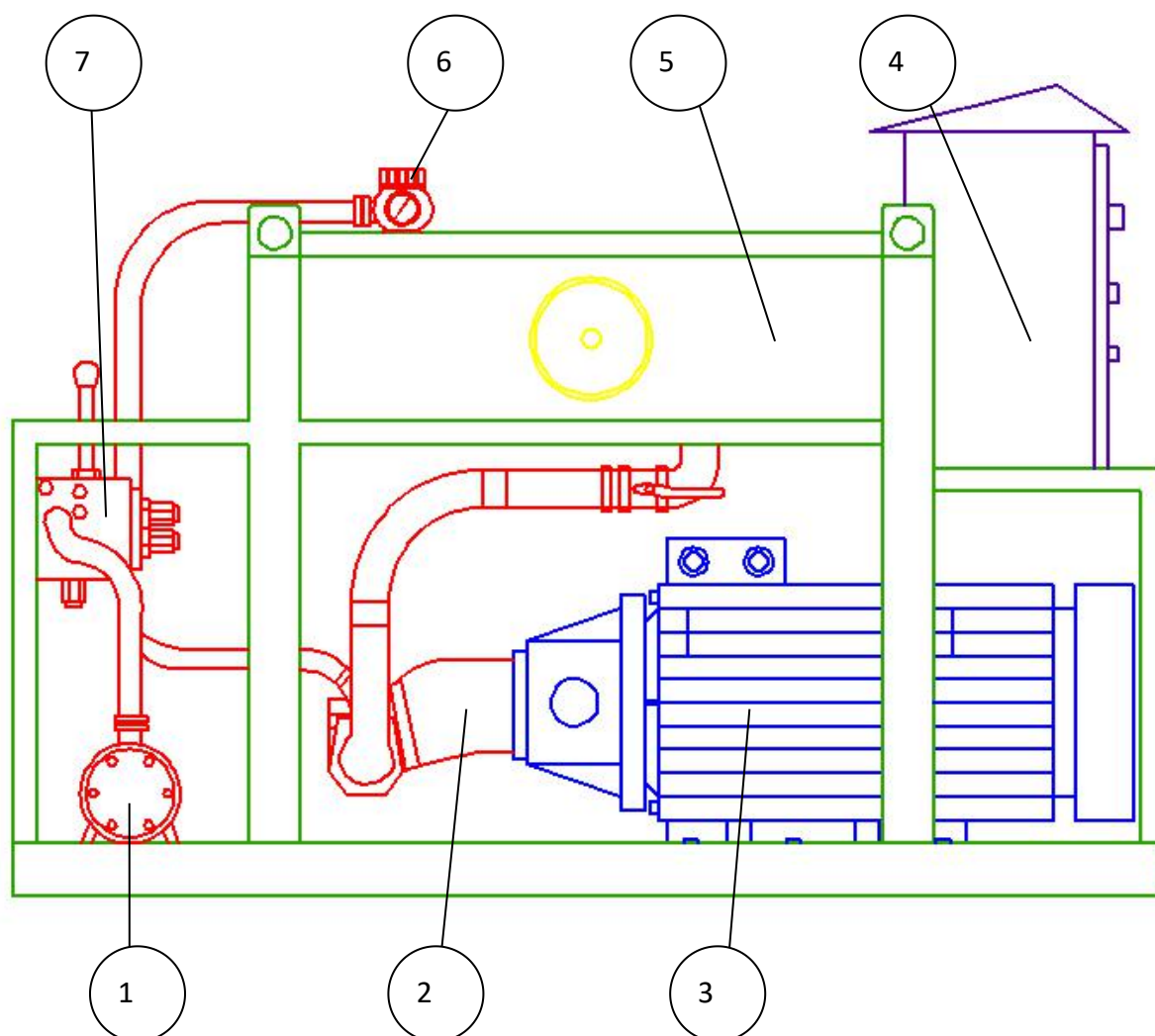

Futech Engineering Trading Co., Ltd.

Workshop: 123C Tin Ha Road, Hung Shui Kiu, Yuen Long, N.T.

Tel: 852-31181665 Fax: 852-31186557

E-mail: sales@chinahydraulic.com Website: www.chinahydraulic.com

Operation Regulations

1. Only allow trained technician who have read this manual to work with this machine.
2. Keep this operation manual on the working site and save a copy in head office.
3. Before start working, check the machine if there is no externally visible damages or faults.
4. Replace hoses if they have been damaged.
5. Supply electricity to power pack first, start the motor for 1 second and then stop it immediately. Check the rotation direction whether it is the same direction as the symbol labeled on motor. If it is not, electrician must switch the pole connection and check the rotation direction to make sure if it is corrected.
6. You may start using the machine after checking. Place the machine cover the the casing first.
7. Connect power pack hoses to Casing Jack-up machine.
8. Switch on the power pack. Wait for 3 minutes and pull the control valve levers to make sure cylinders stroke have not been extended.
9. Push the lever of clamping cylinder to clamp the casing.
10. Push the lever of jack-up cylinder to jack up the casing.
11. After jacking up the casing, pull the lever of clamping cylinder to release the casing. And then pull the lever of jack-up cylinder to jack down the machine.
12. Repeat step(9) until casing can be took out.
13. Pull all the cylinder back to normal position and switch off the motor after finished using the machine.



Futech Engineering Trading Co., Ltd.

Workshop: 123C Tin Ha Road, Hung Shui Kiu, Yuen Long, N.T.

Tel: 852-31181665 Fax: 852-31186557

E-mail: sales@chinahydraulic.com Website: www.chinahydraulic.com

Maintenance Regulations

1. Replace the return filter element every 500 hours, the model is RTE0160F010N.
2. Replace hydraulic oil every 2000 hours.
3. Check the hydraulic cylinder if it has oil leakage, repair it as soon as possible if it happened.
4. Add lubricant oil at the clamping tools moving area in order to reduce friction, working life can be extended.



Futech Engineering Trading Co., Ltd.

Workshop: 123C Tin Ha Road, Hung Shui Kiu, Yuen Long, N.T.

Tel: 852-31181665 Fax: 852-31186557

E-mail: sales@chinahydraulic.com Website: www.chinahydraulic.com